

AB Angle Bracket

Data sheet

Issue Date:
May 2026

The AB are a versatile range of reinforced angle brackets designed for use in 90 degree connections allowing for use of nails, screws and / or bolts and coach screws. Manufactured from 2.5mm thick galvanised steel to BS EN 10346 + G275. Stainless steel grade 304 austenitic to BS EN 10088-2 Grade 1.4301 available from stock in all sizes.

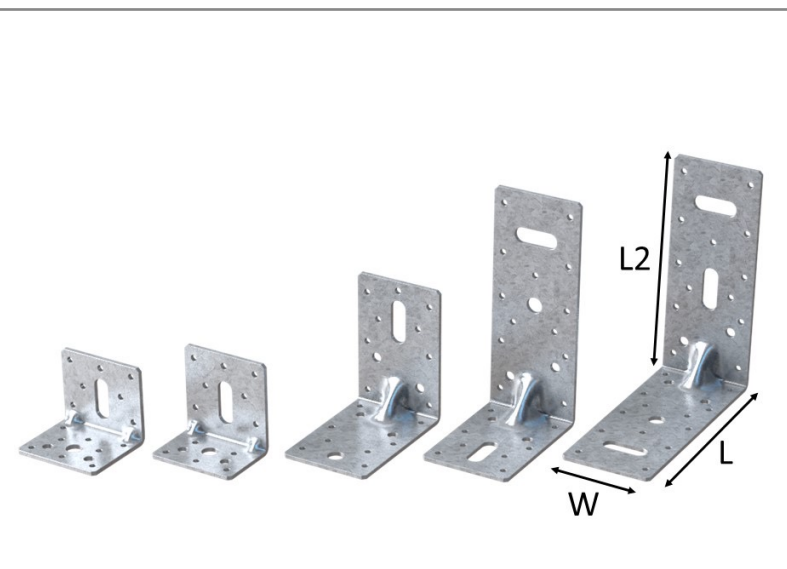

Product

Features:

- Various sizes available
- Stiffening Rib
- Multiple Holes

Fixings:

- Type A, 30 x 3.75mm Sherardised Square Twist Nails
- Type B, 35 x 3.75mm.

Approvals:

- CE Marked
- UKCA Marked

Packaging:

- Box Quantities see table

Load Directions

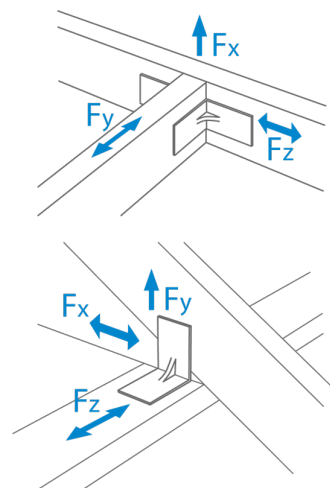

Holes

Product code	Dimensions [mm]			Holes no. x Ø [mm]				Box Quantity
	L	L2	W	Plate 1 (L)		Plate 2 (L2)		
				Holes	Slots	Holes	Slots	
AB/50x50	50	50	60	7 × 4.5	1 × 11.0 × 30.0	8 × 4.5 2 × 7.0 1 × 11.0	-	100
AB/60x40	60	40	60	7 × 4.5	1 × 11.0 × 30.0	5 × 4.5 2 × 7.0	1 × 11.0 × 11.0	100
AB/90x90	90	90	60	9 × 4.5 2 × 9.0	1 × 11.0 × 30.0	8 × 4.5 2 × 9.0	1 × 11.0 × 11.0	100
AB/150x90	150	90	60	13 × 4.5 2 × 9.0 1 × 11.0	1 × 11.0 × 30.0	8 × 4.5 2 × 9.0	1 × 11.0 × 30.0	100
AB/150x150	150	150	60	13 × 4.5 2 × 9.0	2 × 11.0 × 30.0	13 × 4.5 2 × 9.0 1 × 11.0	1 × 11.0 × 30.0	50

Loads

Product code	Characteristic Capacity [kN] - Per pair																	
	C16 timber						C24 timber						TR26 timber					
	Type A nails			Type B nails			Type A nails			Type B nails			Type A nails			Type B nails		
	F _{x,k}	F _{y,k}	F _{z,k}	F _{x,k}	F _{y,k}	F _{z,k}	F _{x,k}	F _{y,k}	F _{z,k}	F _{x,k}	F _{y,k}	F _{z,k}	F _{x,k}	F _{y,k}	F _{z,k}	F _{x,k}	F _{y,k}	F _{z,k}
AB/50x50	3.41	2.09	5.67	3.99	3.81	7.03	3.78	2.36	6.31	4.43	4.30	7.72	3.96	2.49	6.63	4.65	4.55	8.06
AB/60x40	4.10	2.09	5.67	4.78	3.81	7.59	4.54	2.36	6.31	5.31	4.14	7.53	4.76	2.49	6.63	5.58	4.26	7.86
AB/90x90	8.26	2.75	7.84	9.65	4.62	8.77	9.15	3.49	8.64	10.72	4.90	9.34	9.59	3.60	8.83	11.25	5.04	9.55
AB/150x90	8.26	2.96	7.95	9.65	4.62	8.77	9.15	3.49	8.64	10.72	4.90	9.34	9.59	3.60	8.83	11.25	5.04	9.55
AB/150x150	8.26	3.38	8.15	9.65	4.62	8.77	9.15	3.49	8.64	10.72	4.90	9.34	9.59	3.60	8.83	11.25	5.04	9.55

Note: The characteristics load-carrying capacities stated above refer to brackets used in pairs, fixed with nails only.

Note: Refer to fixing data sheet for fixing information.